

# FOUNDRY PRACTICE

APRIL 2016

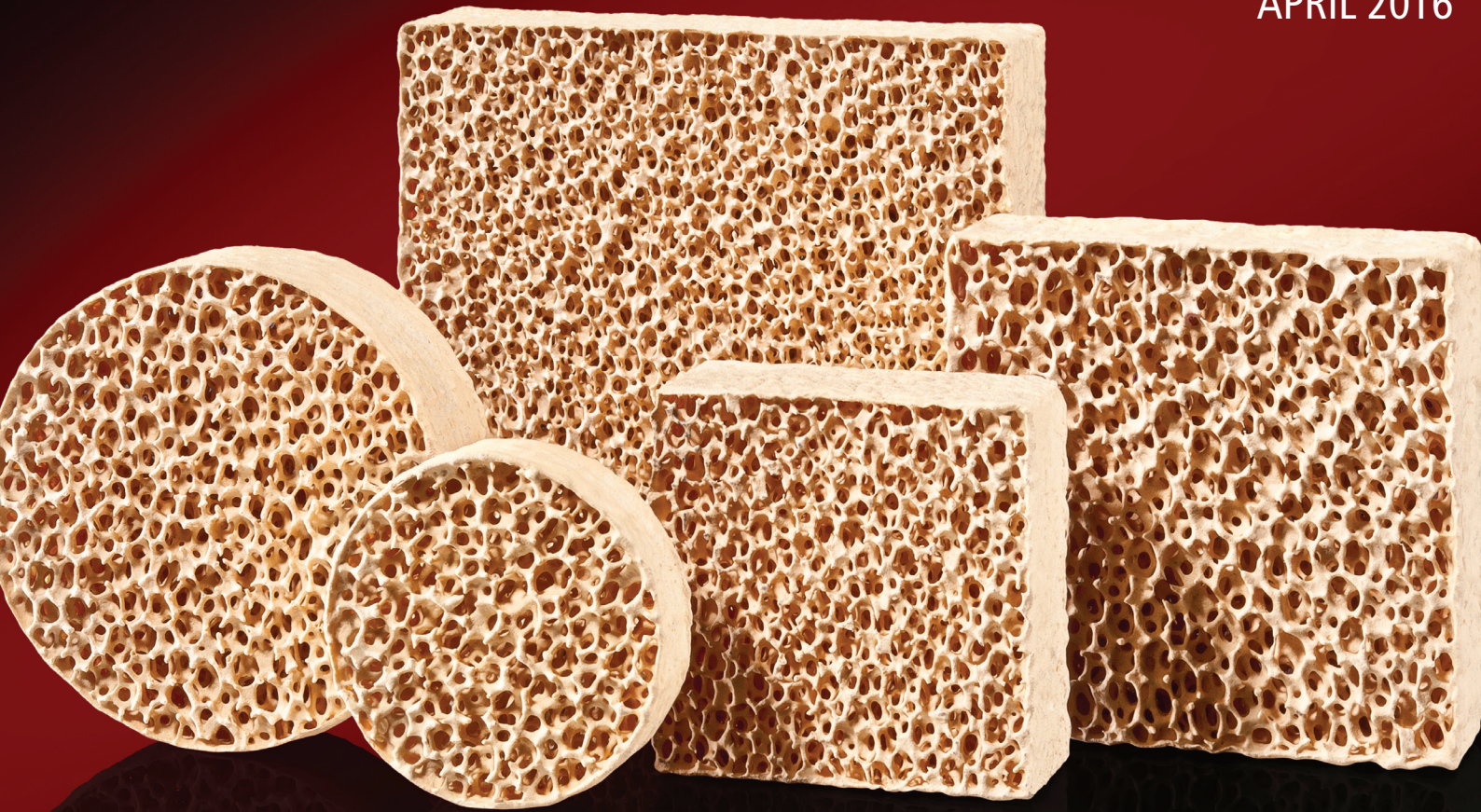

THE AUTHORITATIVE MAGAZINE FOR FOUNDRY ENGINEERS

STELEX\* ZR *ULTRA* - A NEW GENERATION OF CERAMIC FOAM FILTERS



**SPECIAL EDITION**

World Conference in Investment Casting, Paris

April 17th - 20th 2016

# Foundry Practice

The Authoritative Magazine For Foundry Engineers

APRIL 2016

02

## STELEX ZR *ULTRA*

A new generation of ceramic foam filters providing real opportunities for cleaner steel castings

Author: Nick Child, Foseco International Limited



There is a clear market need for a steel casting filtration system that provides a consistent performance in demanding applications together with a desire for enhanced filtration efficiency. The result is the development and introduction of an improved zirconia based ceramic foam filter to compliment the STELEX product range.

# STELEX\* ZR *ULTRA* - A New Generation of Ceramic Foam Filters Providing Real Opportunities for Cleaner Steel Castings

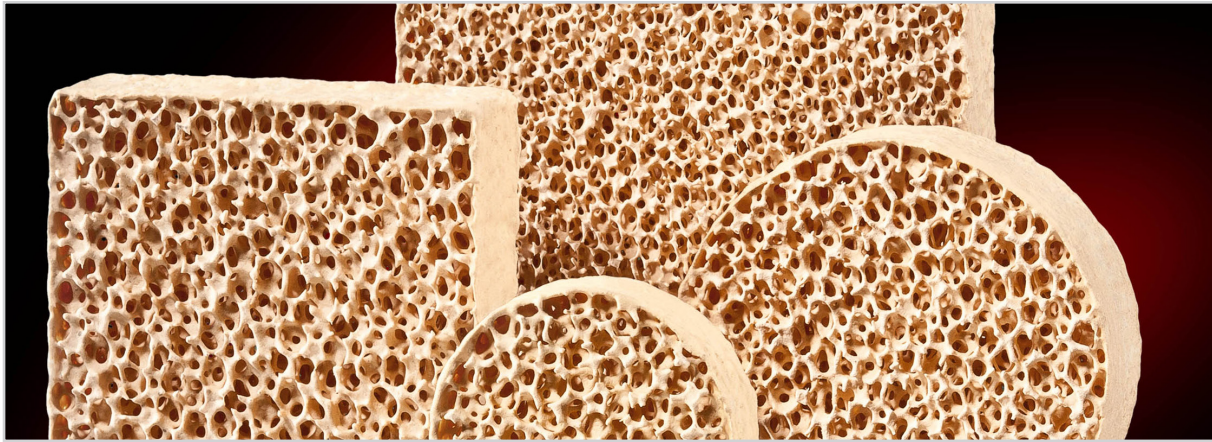

## Background

Many steel castings are sophisticated, high technology components, and are often an important part of complex assemblies and systems for a huge range of applications. The castings are used in many industries, some examples are:

- Railway - for safety critical components including brake and engine parts
- Energy - for high integrity heavy duty safety critical castings including high pressure pumps, valves and nuclear reactor parts
- Military - for high specification castings to be used as structural parts for military platforms and safety critical components in military aircraft.

The complexity and integrity of steel castings that are produced is rapidly increasing and the market demand is not expected to decline. An example is the use of stainless steel castings in the high end automotive industry for turbo charger housings and exhaust manifolds, that can operate at ever increasing temperatures on high efficiency engines.

Ceramic foam filters were first used in the steel casting industry towards the late 1980's and the technology associated with steel filtration systems and application has continually improved. Now, ceramic foam filters are applied in tiny components where the smallest of inclusions will result in the scrapping of the casting, through to castings weighing in excess of 40 Tonnes.

The filters perform two major functions that generate a wide number of benefits for the casting producer:

- Filtration
  - Removing the majority of non-metallic inclusions in the metal stream at the filter face; smaller particles are then trapped by a variety of chemical and physical mechanisms within the filter structure. Various investigations show that filters are in the region of 80% efficient at removing inclusions
- Flow Control
  - Reducing the energy within the metal stream and facilitating low turbulence as the casting cavity fills.

The benefits of filtration of steel castings are well documented and include higher integrity, less scrap, reduced rectification time and costs, improved surface finish and reduced inspection requirement.

The Modern Casting "48th Census of World Casting Production" shows that the global production of steel castings is 11 million tonnes. Market surveys estimate that less than 8% of the global steel casting tonnage is filtered, this relates to over 10 million tonnes of castings not being filtered.

Foseco undertook a market study to understand why the uptake of steel filtration technology has not been more rapid and reached a higher level. There are many reasons that can be cited, including casting size (some castings are currently too big to filter), casting type (some castings can be very low integrity), geography (low labour costs making high levels of repair cost effective). It became apparent that many foundries do use filtration technology but only apply the filters to a limited proportion of the castings they produce; the reason for this includes, concern that the application of the filter will cause problems and inconsistencies during the casting process, particularly in terms of mould fill. It was also noted that there is a clear casting producer demand for higher efficiency filters.

## The Development of STELEX ZR *ULTRA*

There was a clear market need for a steel casting filtration system that provided more consistent performance in demanding applications, together with a desire for enhanced filtration efficiency.

The result is the development and introduction of an improved zirconia based ceramic foam filter to complement the STELEX product range.



Figure 1 - STELEX ZR *ULTRA* Product Range

STELEX ZR *ULTRA* is based on improved zirconia ceramic technology and incorporates a ceramic frame around the sides or the filter. This combination allows the filters to be lower in weight, while maintaining the required strength to withstand the impact and passage of molten steel. The lower weight reduces the occurrence of pore blockage within the filter structure, and facilitates the ability to supply a product with finer porosity that performs consistently. In addition, the frame and robustness of the ceramic provide a filter that exhibits superior friability characteristics and therefore reduces the potential incidence of filter related defects in the casting.

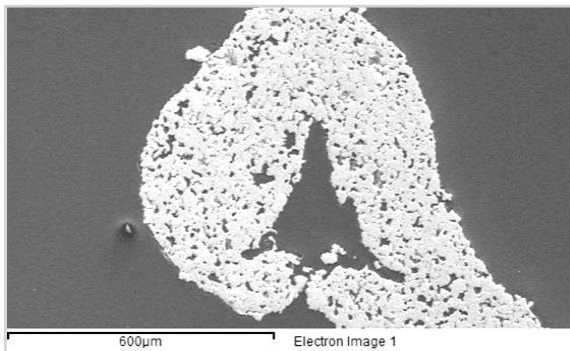

Figure 2 - An electron micrograph showing the highly sintered structure of STELEX ZR *ULTRA*

The new filter is available in two porosities:

- STELEX ZR *ULTRA* 10 - Coarse porosity
- STELEX ZR *ULTRA* 15 - Fine porosity

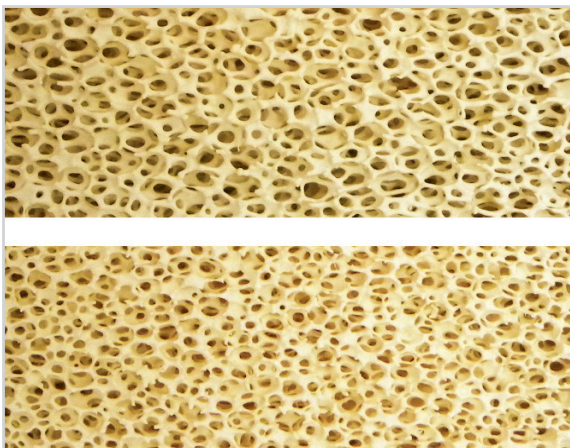

Figure 3

The intention is that STELEX ZR *ULTRA* 10 will provide a filter that consistently primes and provides reproducible performance in terms of metal flow rate and capacity before filter blockage. STELEX ZR *ULTRA* 15 will provide enhanced filtration efficiency where required and will be particularly well suited to high specification, high integrity, high alloy casting applications.

## Characterisation of STELEX ZR *ULTRA*

Foseco uses a wide range of laboratory tests to characterise and benchmark filter products. In addition, tests and evaluations are performed with molten steel in laboratory testing environment and later at customer foundries.

Some of the tests used in the development of STELEX ZR *ULTRA* are detailed here.

### Air Flow / Pressure Drop

#### Principles of the Test

The test is used to measure the resistance of flow as air is sucked through a filter at defined speeds. The air pressure is compared above and below the filter to generate a "Pressure Drop" result. These results provide an indication of the resistance to molten metal flow that a filter will introduce.

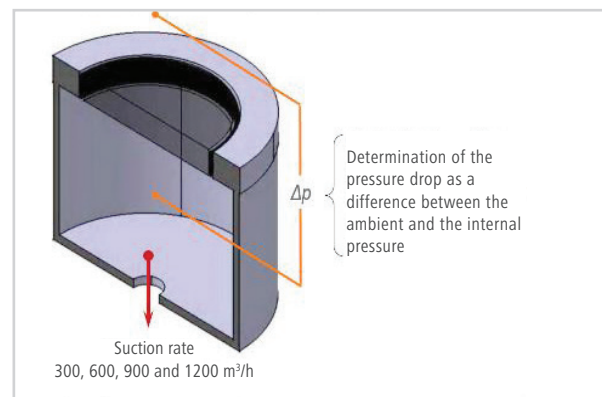

Figure 4 - A diagram showing the principles of the "Pressure Drop Tests"

#### Results of the Test

The test was used to compare the performance of STELEX ZR 10ppi, STELEX ZR *ULTRA* 10 and STELEX ZR *ULTRA* 15. Fifty filters of each type were evaluated and the results presented in the graph.

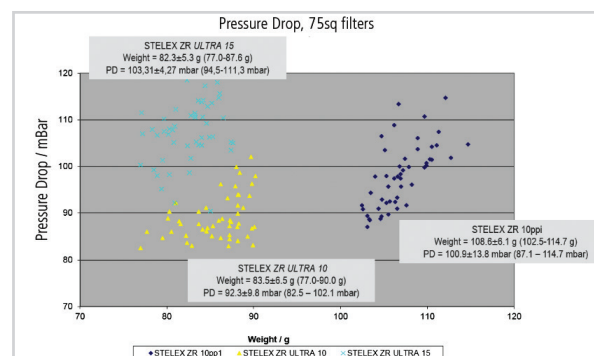

Figure 5 - The results of the pressure drop test

The results show that pressure drop associated with STELEX ZR *ULTRA* 10 is 9% lower (better) than standard STELEX ZR 10ppi, despite the STELEX ZR *ULTRA* 10 porosity being purposefully finer to deliver a higher filtration efficiency. The pressure drop associated with STELEX ZR *ULTRA* 15 is only marginally higher than standard STELEX ZR 10ppi indicating the filters will be suitable for application where it is required to achieve high levels of filtration efficiency with little impact of metal flow. In addition, the spread of the results are lower for the *ULTRA* products giving confidence that more consistent flow rate performance will be experienced when they are applied to the filtration of molten steel.

## Friability

### Principle and description of the test

Ceramic foam filters have a degree of friability, this is related to the shape of the filter, the strands and the ceramic structure. Friability is usually manifested by very small pieces of filter becoming detached from the filter during handling and transport. In its extreme form small pieces of filters may be found in the casting. The most common friability test used by Foseco investigates the effect of vibration applied to a packed carton.



Figure 6

A carton of finished filters is taken from the stores and subject to the test which is summarised as follows;

- The filters are carefully removed from the carton and any pieces that are loose or detached from the filter are collected
- The total weight of the collected pieces is recorded
- The carton is repacked and sealed
- The carton is fixed and strapped to a vibrating table
- Vibration is applied to the carton in a controlled fashion (in respect to frequency and amplitude)
- The filters are again carefully removed from the carton and any pieces that are loose or detached from the filter are collected
- The total weight of the pieces detached by the vibration is recorded.



Figure 7



Figure 8

### Results of the Test

The results from the tests performed on a total of 4 cartons of 75x75 STELEX filters are summarised in the table.

	Number of filters per carton	Average filter weight grams	Weight of filters per carton	Pieces in Carton Before Vibration grams	Friability before Vibration %	Pieces in carton After Vibration grams	Friability after Vibration %
STELEX ZR 75x75x25/10ppi	117	105.5	12344	5.3	0.043	4.0	0.032
	117	105.5	12344	4.1	0.033	3.9	0.032
STELEX ZR ULTRA 10 75x75mm	135	84.5	11408	1.5	0.013	0.8	0.007
	135	84.5	11408	1.3	0.011	0.9	0.008

This shows that there is a 70 - 80% reduction in the apparent friability of STELEX ZR ULTRA 10 compared to standard STELEX ZR before vibration and similarly after vibration.

## Molten Metal Priming Test

### Principle and description of the test

The ability of filters to prime with molten steel (for the steel to pass through the filter without freezing in the filter structure at the beginning of pouring) is an important characteristic. Problems can be experienced with alloys that are poured with minimal superheat above their liquidus temperatures; carbon and low alloy steels are often poured in this way.

Foseco uses a test to measure and compare priming ability of steel filters, the test was defined in conjunction with Castings Technology International.

Five 100x100x25mm filters of a given type are tested in each experiment. The filters are placed in identical moulds that incorporate a filter in a horizontal position at the base of the down sprue. There is a runner directly from the exit of the filter to the side of the mould, a catchment bin is positioned to collect the molten steel as it exits the mould.

Low alloy steel (WCB ASTM 216 (C 0.25%, Si 0.5%, Mn 1%)) is melted and tapped into a KALTEK lined lip pour ladle (KALTEK lining is required to provide the required temperature control). At a predefined metal temperature, about 30kg of molten steel is poured down the sprue and the time for the filter to prime is recorded (the priming time here is defined as the time between the start of the metal being poured and then exiting the mould). The test is then repeated with each of the remaining filters at predefined temperatures as the metal cools in the ladle.



Figure 9 - The priming test

## Results of the Test

In this table the priming results comparing STELEX ZR 10ppi and STELEX ZR *ULTRA* 10 are detailed.

Pouring Temperature Range °C	STELEX ZR 10ppi		STELEX ZR <i>ULTRA</i>	
	Temperature °C	Prime Time Seconds	Temperature °C	Prime Time Seconds
1571 - 1580	1580	5		
1561-1570	1570	5		
1551-1560	1557	Aborted (mould issue)	1551	5
1541-1550	1547	7	1541	7
1531-1540	1540	No Prime	1537	5
1521-1530			1526	10
1511-1520			1517	16

The results clearly show that STELEX ZR *ULTRA* 10 filters prime at significantly lower temperatures than conventional Zirconia filters.

## Molten Metal Capacity and Flow Rate

### Principle and description of the test

It is important that filters provide reproducible and consistent molten metal capacities and flow rates to ensure that the moulds fill within the required time for the casting.

Foseco has defined a test in conjunction with Castings Technology International to measure and record the capacity and flow rate of molten steel through the filters.

A 100x100x25mm filter is applied in a similar mould as used in the Priming Test and a large pouring basin positioned at the top of the sprue. The height of the top of the sprue above the filter is 50cm. The system is designed so that the filter is the choke in the system (the filter is the limiting factor in the rate of metal flow). A catchment pit is positioned below the exit of the mould; this catchment pit is on a set of industrial scales.

600kg of low alloy steel (WCB ASTM 216 (C 0.25%, Si 0.5%, Mn 1%)) is melted and tapped into a bottom pour ladle. The metal is heavily deoxidised (0.08%Al, 0.075% FeSiZr (26% Zr) to generate metal that will have a high concentration of non metallic inclusions which will have the effect of blocking the filter. The ladle is fitted with a 38mm diameter nozzle ensuring the filter will be rate controlling during the metal pouring.

The metal is poured from the ladle at 1600 - 1610°C with the intention of keeping the sprue full, this involves some throttling of the ladle. Outputs from the scale to a computer record the rate at which the metal exits the filter and fills the catchment pit. Metal pouring is stopped after the metal flow rate has fallen below 5kg/s.



Figure 10

## Results of the Test

Typical results to compare a standard STELEX ZR 10ppi filter and a STELEX ZR *ULTRA* 10 filter are shown in the graph.

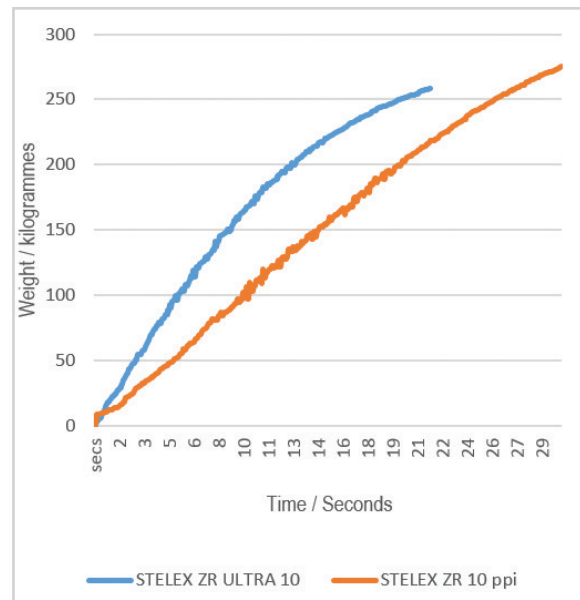

Figure 11

If we compare the amount of metal that has passed through the filters before the flow rate has fallen to 10kg/s and then 5 kg/s, we can generate this table.

Filter type	Weight of metal passing through the filters		Maximum Flow Rate
	Before the flow rate falls below 10kg/s	Before the flow rate falls below 5kg/s	
STELEX ZR 10ppi	218 kg	274 kg	14 kg/s
STELEX ZR <i>ULTRA</i> 10	219 kg	258 kg	19 kg/s

These results show that the capacities of the two filter types are comparable. Initially STELEX ZR *ULTRA* has a higher flow rate, but the filter becomes blocked more rapidly due to the higher filtration efficiency associated with the finer porosity.

## Customer Evaluation

A major European foundry has assisted Foseco by evaluating the STELEX ZR *ULTRA* product and providing feedback on the performance – This foundry is now using high volumes of STELEX ZR *ULTRA* 15 on a production basis.

The customer produces high alloy steel parts for the automotive sector, particularly exhaust manifolds, turbocharger housings and combinations of both. These castings are produced to extremely high quality specifications and will be scrapped for inclusions of less than 1mm in size.

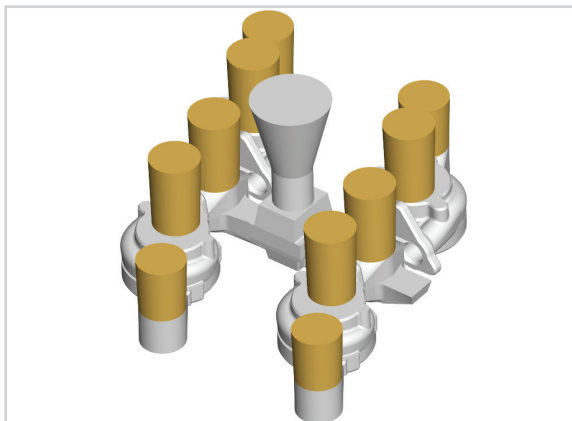

Figure 12

On a specific casting the foundry was using 75x75x25mm 10ppi zirconia foam filters but was still suffering a reject rate of over 2% for a combination of slag defects and particles of filter, due to filter friability. Previously the foundry had tried to use finer filters but these had not been accepted as they introduced metal pouring and flow associated problems. The foundry initially assessed 400 units of STELEX ZR *ULTRA* 15, the results of the experiment are shown in the table.

### Casting Information

Casting: Turbocharger housing

Metal grade: Stainless Steel

Gross weight: 32 kg

Pouring temperature: 1630 - 1640 °C

Desired pouring time: 3 - 4 seconds

	10 ppi Filter	STELEX ZR ULTRA 15
Pouring Time / Seconds	2.8 - 3.1	3.3 - 4.0
Number of castings produced	63.000	400
Reject rate after machining	2.1%	0.5%

## Conclusion

Market Research identified that there is a need to improve ceramic foam filter technology for application to steel castings that will provide a more robust solution with consistent performance in application particularly associated with mould fill.

It also showed there was a desire for ceramic foam filters that would provide enhanced filtration performance over the established 10ppi products which cause difficulties in other aspects of the casting process.

Through a combination of filter framing and ceramic technology, Foseco is introducing STELEX ZR *ULTRA* 10 and STELEX ZR *ULTRA* 15 to complement their other steel filtration offerings, which include STELEX ZR, PrO, KALPUR\* and HOLLLOTEX\*.

### STELEX ZR *ULTRA* filters provide the benefits including:

- + Reduced potential for flow related defects
  - consistent capacity and flow rates of metal through the filter
  - improved priming through less metal chill as the filter primes
- + Potential for enhanced casting cleanliness
  - the use of finer filters with molten steel where previously this had not been possible
  - greater filtration efficiency and the potential for a higher level of turbulence control
  - reduction in the possibility of metal bypassing the filter
  - very low friability reducing the potential for filter inclusions in the casting



**14th WORLD  
CONFERENCE ON  
INVESTMENT CASTING**  
**17-20 APRIL 2016**

All rights reserved. No part of this publication may be reproduced, stored in a retrieval system of any nature or transmitted in any form or by any means, including photocopying and recording, without the written permission of the copyright holder.

All statements, information and data contained herein are published as a guide and although believed to be accurate and reliable (having regard to the manufacturer's practical experience) neither the manufacturer, licensor, seller nor publisher represents or warrants, expressly or impliedly:

- (1) their accuracy/reliability
- (2) that the use of the product(s) will not infringe third party rights
- (3) that no further safety measures are required to meet local legislation

The seller is not authorised to make representations nor contract on behalf of the manufacturer/licensor. All sales by the manufacturer/seller are based on their respective conditions of sale available on request.

\*FOSECO, the logo, KALTEK and STELEX are Trade Marks of the Vesuvius Group, registered in certain countries, used under licence.

© Foseco International Ltd. 2015

COMMENT

Editorial policy is to highlight the latest Foseco products and technical developments. However, because of their newness, some developments may not be immediately available in your area. Your local Foseco company or agent will be pleased to advise.

**Foseco International Limited**  
P.O. Box 5516  
Tamworth  
Staffordshire  
England B78 3XQ  
Registered in England No. 468147

Produced in England

